



TEST REPORT

According to ANSI/IES LM-80-15
For

Hongli Zhihui Group Co.,Ltd. Guangzhou Branch

Room 316, Building 2, No.1, Xianke Yi Road, Huadong Town, Huadu District, Guangzhou, China

Model: HL-C3535K9W1EA(Ra1)-FC

Report Type: 6000 Hours Test Report		Product Type: LED Package	
Reviewed By:	Pote Wang	<i>Pote Wang</i>	
Report Number:	RSZ201026503-10-6000		
Test Date:	2020-11-23 to 2021-08-20		
Report Date:	2021-10-11		
Approved by:	Bill Xiong / EE Engineer		
Prepared By:	Bay Area Compliance Laboratories Corp. (Dongguan). No.12, Pulong East 1 st Road, Tangxia Town, Dongguan, Guangdong, China. Tel: +86-0769-86858888 Fax:+86-0769-86858588		



1 - General Information

1.1 Description of LED Light Sources

Sample Size:

60 PCS test samples were in good condition and received on 2020-10-26. The samples were numbered from 1 to 30 and 31 to 60.

Manufacturer:	Hongli Zhihui Group Co.,Ltd. Guangzhou Branch
Part Number:	HL-C3535K9W1EA(Ra1)-FC
Part Type:	LED Package
#Drive Level:	DC 800mA
#Nominal CCT:	2700K
#Power:	2.34 W
#Average Current Density per LED die:	410mA/mm ²
#Average Power Density per LED die:	1.2W/mm ²
#CRI:	70
#Die Spacing:	NA

Sampling Method:

LED samples for IESNA LM-80 testing consist of units built from a minimum of three manufacturing lots with each manufacturing lot built from different wafer lots built on non-consecutive days.

These manufacturing lots are picked to represent a wide parametric distribution.

Family products covered by this report:

According to *ENERGY STAR[®] Requirements for the Use of LM-80 Data*, the following products can be covered by this report base on the information and declaration provided by manufacturer. The information of these models shows that the covered products meet all section 4 requirements of *ENERGY STAR[®] Requirements for the Use of LM-80 Data* (September 28, 2017)

This report covers the following models:

Model Name	Total Input Current (mA)	Power (W)	CCT (K)	Number of dies	Driver current per die(mA)	Current Density per Die (mA/mm ²)	Power Density per PCB (W/mm ²)	Die Spacing (mm)
HL-C3535K9W1EA(Ra1)-FC	800	2.34	2700	1	800	410	0.1932	/
HL-C3535K9W1EA(Ra1)-FC	800	2.34	2700-6500	1	800	410	0.1932	/
HL-C3535K9W1EA(Ra1)-FC-LVR	800	2.34	2700-6500	1	800	410	0.1932	/
HL-C3535F77W1EA(Ra1)-FC	500	1.4	2700-6500	1	500	383	0.1176	/
HL-C3535F77W1EA(Ra1)-FC-LVR	500	1.4	2700-6500	1	500	383	0.1176	/
HL-C3535K9W1GA(Ra1)-FC	800	2.34	2700-6500	1	800	410	0.1932	/
HL-C3535K9W1GA(Ra1)-FC-LVR	800	2.34	2700-6500	1	800	410	0.1932	/
HL-C3535F77W1GA(Ra1)-FC	500	1.4	2700-6500	1	500	383	0.1176	/
HL-C3535F77W1GA(Ra1)-FC-LVR	500	1.4	2700-6500	1	500	383	0.1176	/
HL-C3535K9W1EA(Ra1)-FC(Ag60)	800	2.34	2700-6500	1	800	410	0.1932	/
HL-C3535F77W1EA(Ra1)-FC(Ag60)	500	1.4	2700-6500	1	500	383	0.1176	/
HL-C3535K9W1EA(Ra1)-FC(Au120)-CY	800	2.34	2700-6500	1	800	410	0.1932	/
HL-C3535F77W1EA(Ra1)-FC(Au120)-CY	500	1.4	2700-6500	1	500	383	0.1176	/
HL-C3535K9W1GA(Ra1)-FC(Au120)-CY	800	2.34	2700-6500	1	800	410	0.1932	/



Model Name	Total Input Current (mA)	Power (W)	CCT (K)	Number of dies	Driver current per die(mA)	Current Density per Die (mA/mm ²)	Power Density per PCB (W/mm ²)	Die Spacing (mm)
HL-C3535F77W1GA(Ra1)-FC(Au120)-CY	500	1.4	2700-6500	1	500	383	0.1176	/
HL-C3535K9W3GA(Ra1)-FC	800	2.34	2700-6500	1	800	410	0.1932	/
HL-C3535F77W3GA(Ra1)-FC	500	1.4	2700-6500	1	500	383	0.1176	/
HL-C3535K9W5GA(Ra1)-FC	800	2.34	2700-6500	1	800	410	0.1932	/
HL-C3535F77W5GA(Ra1)-FC	500	1.4	2700-6500	1	500	383	0.1176	/
HL-C3535K9W3GA(Ra1)-FC-LVR	800	2.34	2700-6500	1	800	410	0.1932	/
HL-C3535F77W3GA(Ra1)-FC-LVR	500	1.4	2700-6500	1	500	383	0.1176	/
HL-C3535K9W5GA(Ra1)-FC-LVR	800	2.34	2700-6500	1	800	410	0.1932	/
HL-C3535F77W5GA(Ra1)-FC-LVR	500	1.4	2700-6500	1	500	383	0.1176	/
HL-C3535K9W1GA(Ra1)-FC-LVR-QX	800	2.34	2700-6500	1	800	410	0.1932	/
HL-C3535F77W5GA(Ra1)-FC-LVR-QX	500	1.4	2700-6500	1	500	383	0.1176	/

1.2 Standards and Reference Documentations

ANSI/IES LM-80-15: IES Approved Method for Measuring Lumen Maintenance of LED Light Sources.
CIE 127:2007: Measurement of LEDs
ENERGY STAR[®] Requirements for the Use of LM-80 Data (This standard was not accredited by IAS)

1.3 Testing Equipment

Device	Manufacture	Model No	Serial No	Calibration date	Calibration due date
High Accuracy Array Spectroradiometer	EVERFINE	HAAS 2000	P600674CM5391140	2020-10-22	2021-10-21
0.5M Integrating Sphere	EVERFINE	0.5m	NA	2020-10-22	2021-10-21
LED Test Source	EVERFINE	LTS-300	P185616CJ1391143	2020-10-21	2021-10-20
Standard Light Source	EVERFINE	D062	1011093	2020-10-20	2021-10-19
High Accuracy Array Spectroradiometer	EVERFINE	HAAS 2000	P600674CM5391140	2020-10-22	2021-10-21
Multilayer aging machine	BACL	B2-270	20022	2021-02-24	2022-02-23
Digital CC&CV DC Power Supply	EVERFINE	WY5015	11090009	2021-02-24	2022-02-23

1.4 Drive Level

Samples are driven with a constant direct current (DC) during maintenance test, photometric and electrical measurement. The current value was regulated to within $\pm 3\%$ of the specified value of the manufacturer during maintenance test, and was within $\pm 0.5\%$ during photometric and electrical measurement test.



1.5 Ambient Conditions for Maintenance Test

For lumen maintenance test, samples within one data set, were installed on cooling boards in thermal chambers with minimal ambient airflow. The case temperature and ambient temperature was monitored by thermocouples which one was soldered to the LED location, while the other is mounted at a distance of 5 mm above the TMP location.

During life testing, TMP_{LED} of the coldest LEDs were maintained at a temperature that was greater than or equal to 2°C below the corresponding nominal case temperature. Surrounding air was maintained at a temperature that was greater than or equal to 5°C below the corresponding nominal case temperature. Thermocouples were shielded from direct DUT optical radiation and comply with

Samples were connected to DC power supply in series circuits with a constant current. The forward current was regulated to within $\pm 3\%$ of the specified value of the manufacturer.

The relative humidity within chamber was kept less than 65% during test.

For photometry measurement, the ambient temperature during test was set to $25^{\circ}\text{C} \pm 2^{\circ}\text{C}$, RH <65%.

1.6 Photometric Measurement Method and Uncertainty

Integrating sphere and spectroradiometer is used to measure luminous flux and chromaticity coordinate $u.v.2$ measurement was used and sample was driven by DC power supply. The forward current was regulated to within $\pm 0.5\%$ of the

FINAL



3 - Test Data

3.1 Data Set 1, 55°C, 800mA (Lumen Maintenance)

No.	Lumen Maintenance (%)						
	0hr(Initial)	1000hrs	2000hrs	3000hrs	4000hrs	5000hrs	6000hrs
1	338.80	100.32	99.94	99.76	99.32	99.17	99.03
2	333.70	100.30	100.18	99.88	99.58	99.22	99.01
3	335.80	100.21	99.97	99.64	99.43	99.08	98.90
4	336.80	100.24	99.94	99.61	99.41	99.20	98.90
5	335.60	100.39	100.09	99.70	99.34	99.20	99.02
6	335.30	100.39	100.15	99.76	99.61	99.25	99.05
7	338.00	100.65	100.38	99.88	99.70	99.56	99.26
8	334.90	100.36	100.00				
9							

FINAL



3.2 Data Set 1, 55°C, 800mA (Forward Voltage)

No.	Forward Voltage (V)						
	0hr(Initial)	1000hrs	2000hrs	3000hrs	4000hrs	5000hrs	6000hrs
1	2.910	2.927	2.928	2.921	2.911	2.924	2.928
2	2.920	2.939	2.939	2.936	2.958	2.961	2.957
3	2.907	2.923	2.922	2.921	2.917	2.929	2.932
4	2.908	2.923	2.923	2.917	2.916	2.947	2.930
5	2.925	2.931	2.932	2.934	2.935	2.948	2.937
6	2.922	2.935	2.940	2.931	2.943	2.922	2.921
7	2.924	2.939	2.938	2.944	2.930	2.931	2.940
8	2.925	2.936	2.935	2.927	2.935	2.952	2.936
9	2.919	2.939	2.936	2.942	2.947	2.937	2.936
10	2.920	2.936	2.933	2.934	2.934	2.952	2.958
11	2.926	2.941	2.939	2.935	2.943	2.945	2.941
12	2.917	2.933	2.934	2.931	2.931	2.957	2.952
13	2.903	2.925	2.923	2.928	2.927	2.926	2.926
14	2.916	2.932	2.933	2.925	2.934	2.947	2.952
15	2.906	2.920	2.919	2.913	2.927	2.908	2.926
16	2.914	2.931	2.928	2.923	2.933	2.937	2.939
17	2.919	2.934	2.933	2.923	2.947	2.948	2.937
18	2.915	2.930	2.930	2.920	2.926	2.917	2.927
19	2.929	2.945	2.943	2.934	2.936	2.941	2.945
20	2.904	2.916	2.915	2.908	2.917	2.921	2.930
21	2.926	2.941	2.939	2.928	2.928	2.924	2.928
22	2.919	2.933	2.932	2.922	2.916	2.931	2.928
23	2.919	2.933	2.933	2.925	2.920	2.943	2.931
24	2.929	2.946	2.944	2.946	2.936	2.926	2.926
25	2.929	2.947	2.944	2.947	2.939	2.946	2.941
26	2.919	2.932	2.931	2.927	2.919	2.915	2.921
27	2.917	2.933	2.934	2.923	2.919	2.937	2.920
28	2.917	2.934	2.934	2.923	2.919	2.929	2.909
29	2.902	2.918	2.915	2.906	2.916	2.925	2.929
30	2.906	2.921	2.922	2.913	2.917	2.926	2.924
Avg.	2.917	2.932	2.932	2.927	2.929	2.935	2.934
Med.	2.919	2.933	2.933	2.926	2.929	2.934	2.931
st dev	0.008	0.008	0.008	0.010	0.012	0.013	0.011
Min.	2.902	2.916	2.915	2.906	2.911	2.908	2.909
Max.	2.929	2.947	2.944	2.947	2.958	2.961	2.958



3.3 Data Set 1, 55°C, 800mA (Chromaticity Shift)

No.			CCT(K)						
	Ohr(Initial)			1000hrs	2000hrs	3000hrs	4000hrs	5000hrs	6000hrs
1	0.2569	0.5219	54	0.0003	0.0003	0.0011	0.0011	0.0013	0.0013
2	0.2590	0.5271	60	0.0004	0.0005	0.0007	0.0007	0.0008	0.0011
3	0.2604	0.5281	62	0.0006	0.0006	0.0006	0.0006	0.0008	0.0009
4	0.2565	0.5225	2853	0.0004	0.0004	0.0006	0.0006	0.0009	0.0010
5	0.2592	0.5265	2773	0.0003	0.0004	0.0009	0.0009	0.0010	0.0012
6	0.2586	0.5264	2787	0.0004	0.0005	0.0006	0.0006	0.0007	0.0009
7	0.2580	0.5284	2790	0.0004	0.0005	0.0007	0.0007	0.0009	0.0010
8	0.2594	0.5253	2774	0.0004	0.0005	0.0006	0.0006	0.0008	0.0009
9	0.2572	0.5223	2838	0.0003	0.0004	0.0008	0.0008	0.0010	0.0010
10	0.2591	0.5282	2768	0.0004	0.0004	0.0008	0.0008	0.0010	0.0011
11	0.2601	0.5295	2741	0.0004	0.0005	0.0006	0.0006	0.0008	0.0011
12	0.2588	0.5266	2781	0.0005	0.0005	0.0006	0.0006	0.0009	0.0011
13	0.2601	0.5259	2756	0.0003	0.0004	0.0008	0.0008	0.0009	0.0011
14	0.2567	0.5234	2843	0.0004	0.0005	0.0005	0.0005	0.0008	0.0010
15	0.2596	0.5275	2761	0.0004	0.0004	0.0006	0.0006	0.0008	0.0010
16	0.2624	0.5304	2689	0.0004	0.0004	0.0007	0.0007	0.0009	0.0011
17	0.2589	0.5253	2786	0.0004	0.0005	0.0008	0.0008	0.0011	0.0013
18	0.2593	0.5288	2760	0.0004	0.0004	0.0008	0.0008	0.0011	0.0011
19	0.2593	0.5279	2764	0.0004	0.0004	0.0007	0.0007	0.0010	0.0012
20	0.2577	0.5234	2821	0.0004	0.0004	0.0008	0.0008	0.0009	0.0011
21	0.2595	0.5248	2774	0.0004	0.0003	0.0007	0.0007	0.0010	0.0012
22	0.2572	0.5225	2837	0.0004	0.0006	0.0005	0.0005	0.0008	0.0008
23	0.2601	0.5276	2748	0.0003	0.0004	0.0006	0.0006	0.0009	0.0011
24	0.2600	0.5307	2739	0.0003	0.0004	0.0006	0.0006	0.0008	0.0013
25	0.2595	0.5268	2766	0.0004	0.0004	0.0005	0.0005	0.0008	0.0012
26	0.2601	0.5279	2749	0.0003	0.0004	0.0006	0.0006	0.0008	0.0011
27	0.2599	0.5245	2768	0.0004	0.0004	0.0009	0.0009	0.0011	0.0012
28	0.2575	0.5237	2823	0.0005	0.0005	0.0006	0.0006	0.0008	0.0011
29	0.2588	0.5272	2778	0.0004	0.0005	0.0006	0.0006	0.0009	0.0011
30	0.2606	0.5269	2742	0.0004	0.0004	0.0009	0.0009	0.0012	0.0013
Avg.	0.2590	0.5263	2506	0.0004	0.0004	0.0007	0.0007	0.0009	0.0011
Med.	0.2593	0.5267	2768	0.0004	0.0004	0.0007	0.0007	0.0009	0.0011
st dev	0.0013	0.0024	831	0.0001	0.0001	0.0001	0.0001	0.0001	0.0001
Min.	0.2565	0.5219	54	0.0003	0.0003	0.0005	0.0005	0.0007	0.0008
Max.	0.2624	0.5307	2853	0.0006	0.0006	0.0011	0.0011	0.0013	0.0013

4 - DUT Photo

4.1 Mechanical Dimensions

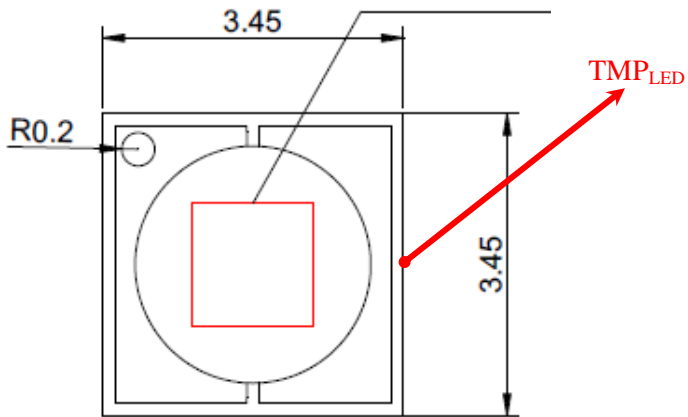

+ -

All dimensions are in millimeter

4.2 DUT Photo

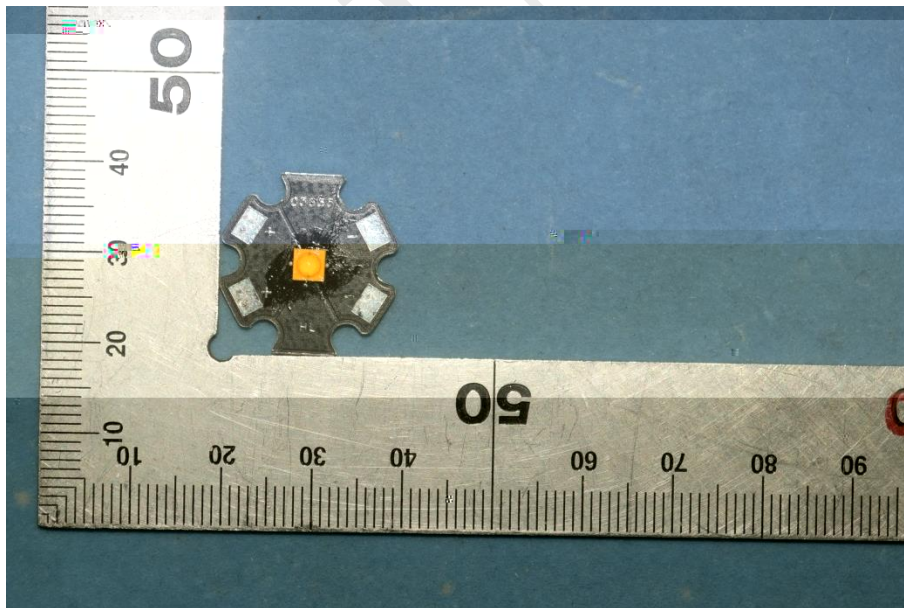



Directions

1. The information marked “superscript #” is provided by the applicant, the laboratory is not responsible for its authenticity and this information can affect the validity of the result in the test report.
2. Unless otherwise stated the results shown in this test report refer only to the sample(s) tested.
3. Otherwise required by the applicant or Product Regulations, Decision Rule in this report did not consider the uncertainty.
4. The extended uncertainty given in this report is obtained by combining the standard uncertainty times the coverage factor K with the 95% confidence interval.
5. This report cannot be reproduced except in full, without prior written approval of the Company.
6. This report is valid only with a valid digital signature. The digital signature may be available only under the Adobe software above version 7.0.

*****END OF REPORT*****